



Expert Solutions for Transport Unloading

MH6 SCREW COMPRESSOR

Transferred by



Powered by



Hydrocar
Hydraulic Energy

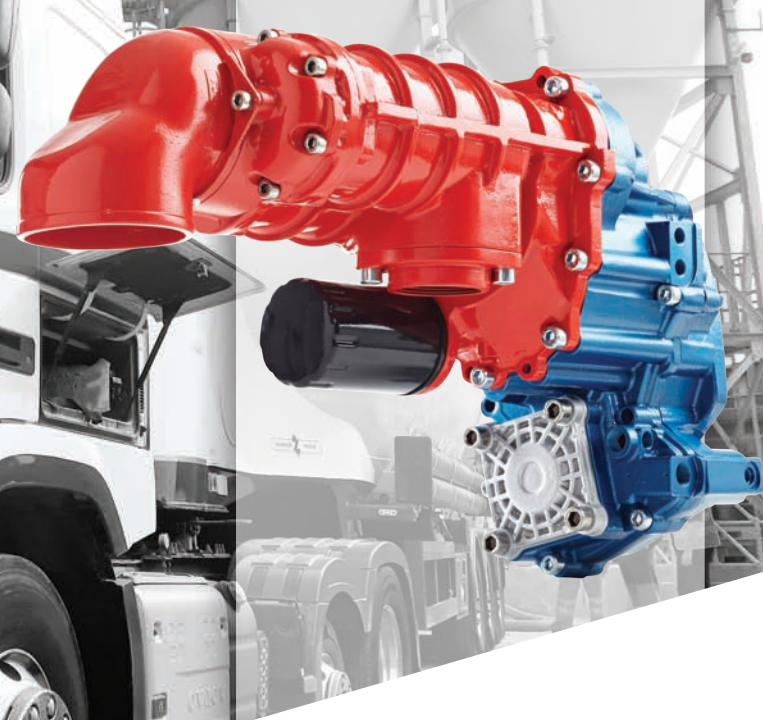

Where Innovation Flows

SCREW COMPRESSOR



mouvex.com



mh⁶ Screw Compressor

A unique and revolutionary concept of integrating the compressor to the transmission

MOUVEX® has been developing innovative products for over 100 years improving performance, compatibility and security.

The MH6 is the ultimate evolution of screw compressor silo unloading. It is safe, lightweight, compact and quiet during operation.

The MH6 pushes the limits by being compatible with most trucks including those with LNG engines.

Dimensions :

L 604 x H 358 x W 280 mm (L 24 x H 14 x W 11 in.)

Weight:

30 + 16 = 46 kg (66 + 35 = 101 lbs.)

Compatible with:

DAF, IVECO, MAN (ZF), MERCEDES BENZ, RENAULT TRUCKS, VOLVO, SCANIA

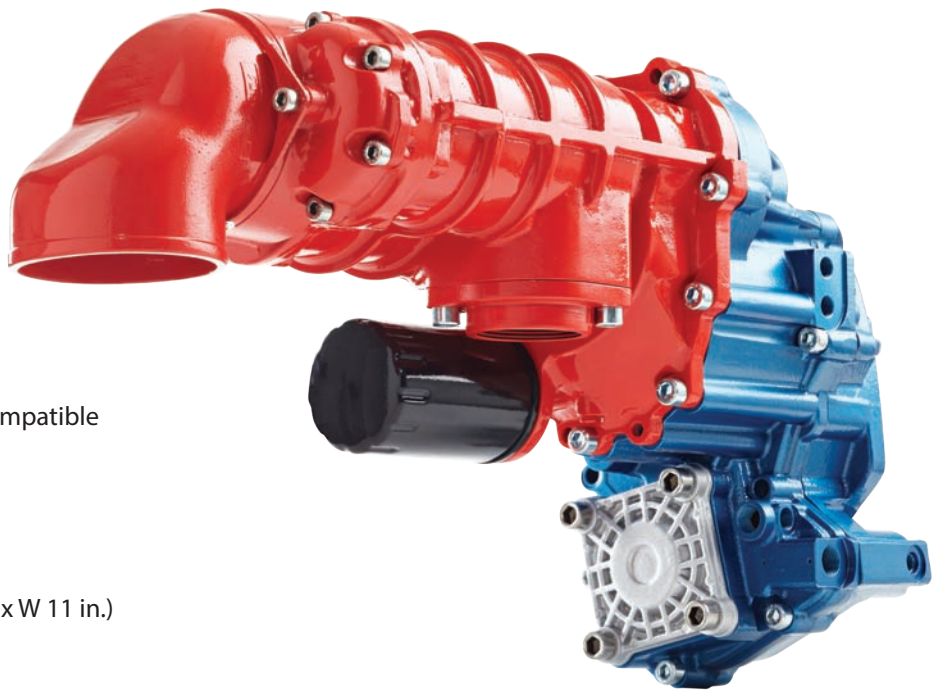

Compressor Module

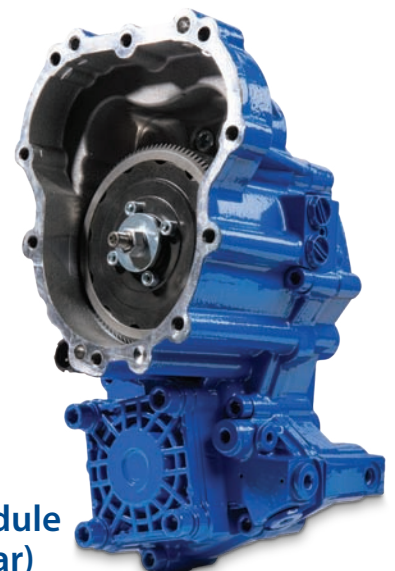

PTO Module (Hydrocar)



mh⁶ Screw Compressor

Flow Rate (m³/h)

Power (kW)

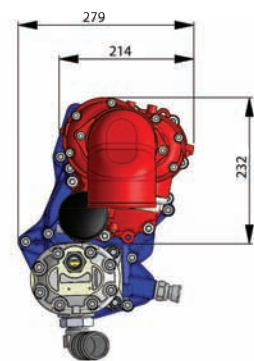
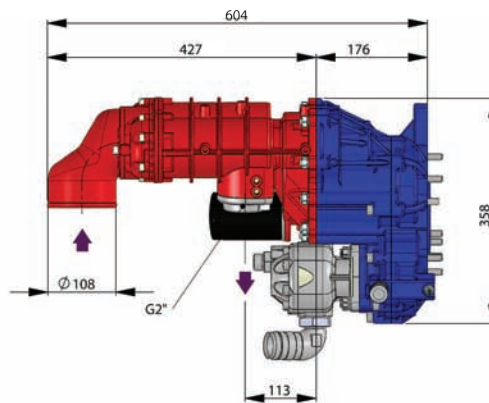
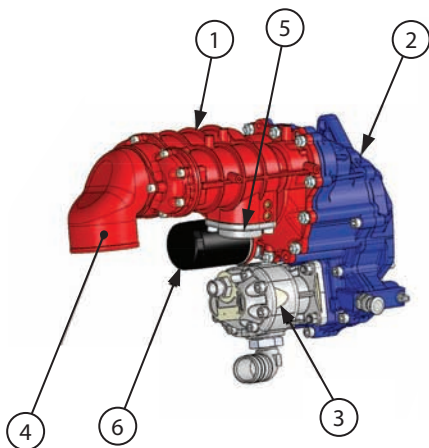
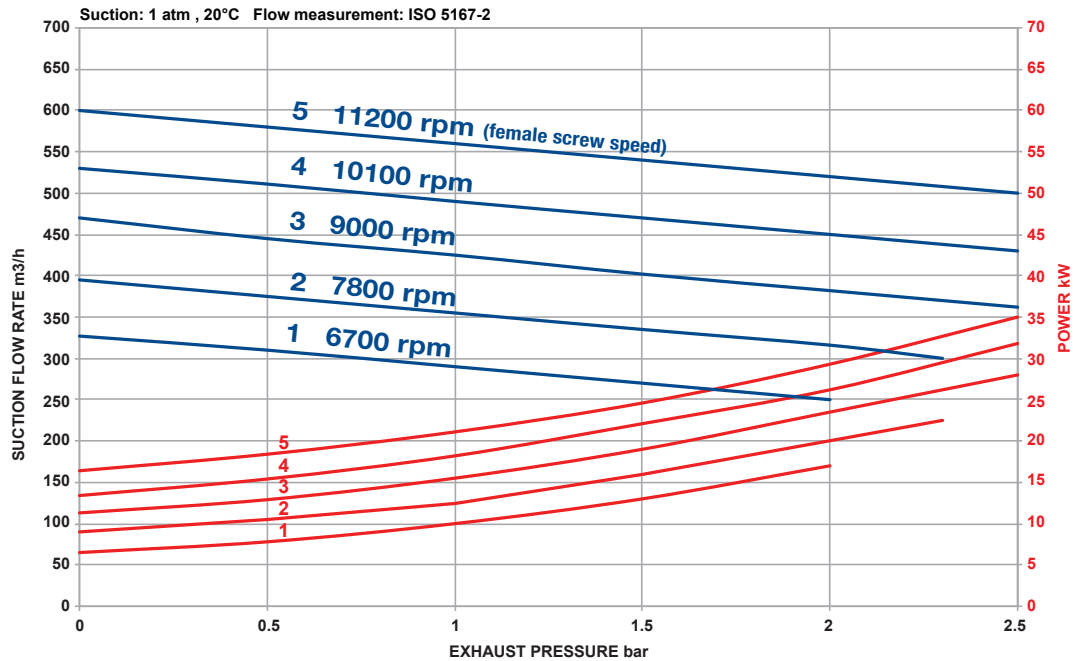

Inlet Port Configurations

1. Compressor
2. PTO / Power Take-Off
3. Hydraulic pump (option)
4. Inlet port
5. Outlet port
6. Oil filter



Rotary Elbow



Compact Elbow



Nipple

The Most Lightweight, Compact, Quietest System on the Market



Direct mounting of the compressor assembly on the gearbox

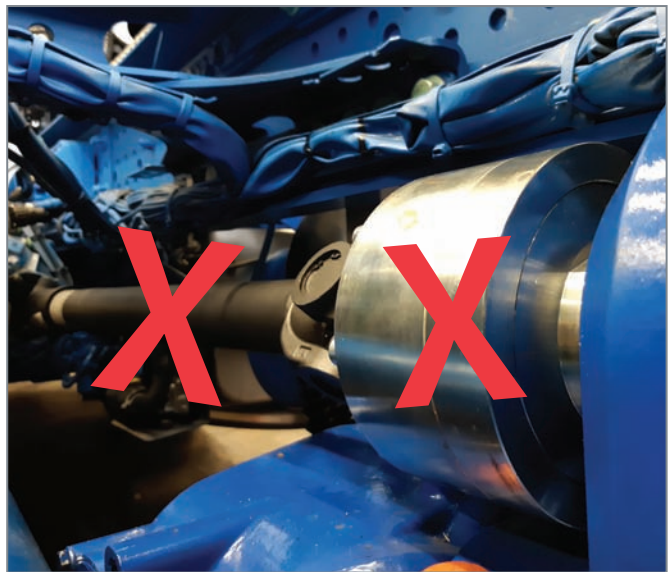

No gimbals needed
No torque limiter

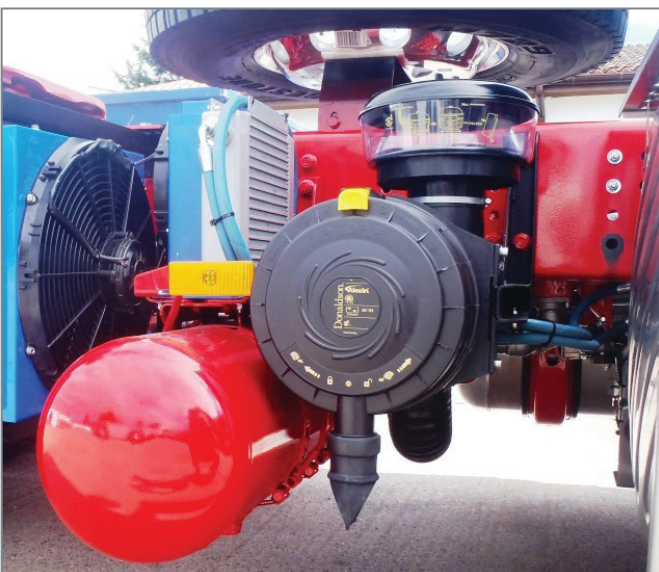

Accessories can be easily installed in available areas

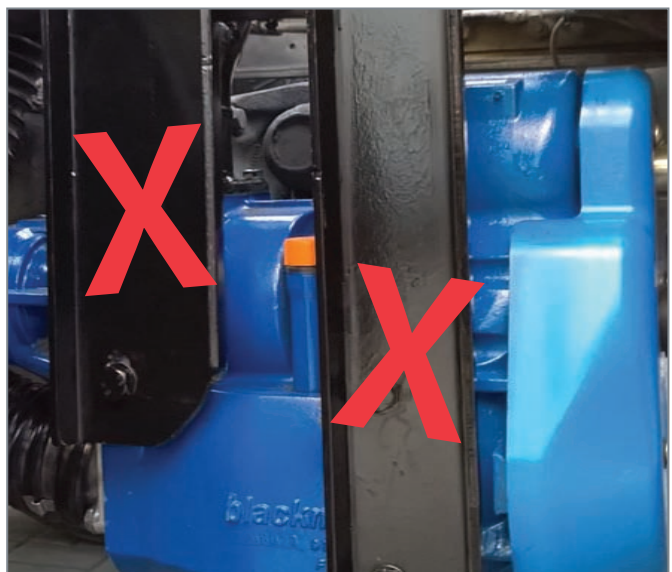

No holder required



The Optimal Solution for Unloading Cement and Construction Materials

- Direct mounting on gear box
- Very compact
- Lightweight
- Extremely Quiet
- No gimbals needed
- No torque limiter
- No holder required



The Unloading Compressor Specialist

MOUVEX COMPRESSOR TECHNOLOGY

- No contact
- Oil-free, particle-free
- Compact
- High volume
- Wide gear range

HYDROCAR PTO TECHNOLOGY

- "Plug and Play" installation
- No gimbals needed
- No holder required
- Integrated torque-limiter

EASY OPERATION

- Reduced engine speed
- Reduced maintenance
- Enhanced safety, no rotating body
- 2-year warranty
- Installation compatible with all diesel trucks using 4x2 standard short chassis, 6x2 and 6x4 trucks





mh⁶

Screw Compressor & Accessories



Check relief valve

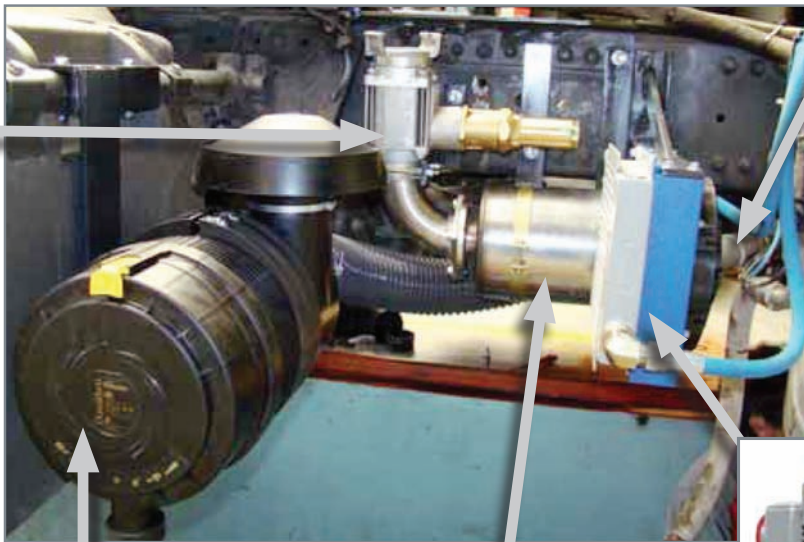

Discharge hose



Air filter assembly



Muffler assembly



Oil cooler (supplied with flexible hoses)



Torque limiter integrated into the PTO module

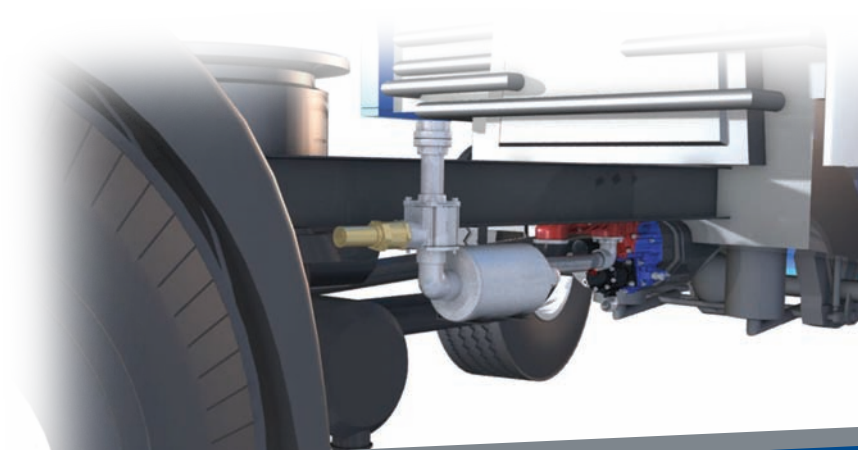

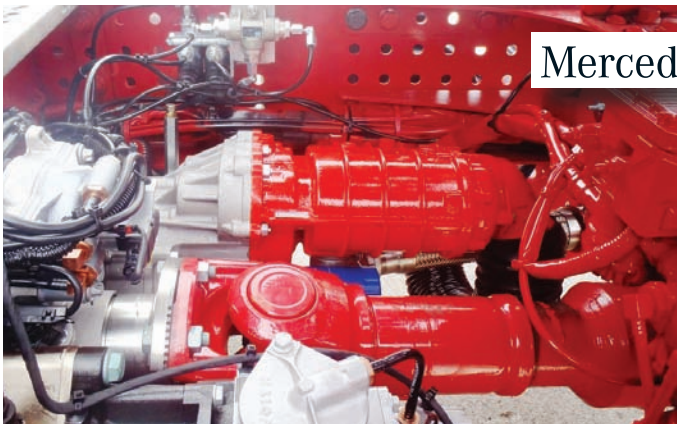

Mercedes-Benz



DAF

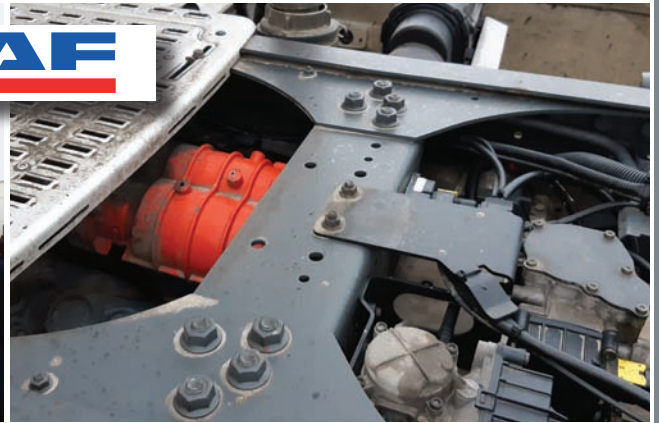

IVECO



VOLVO

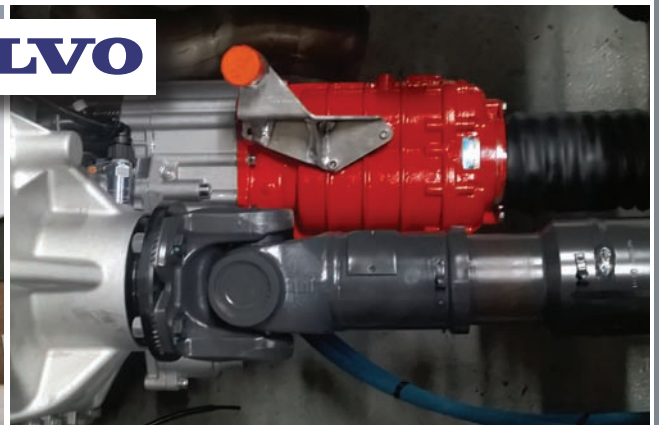



ZI la Plaine des Isles • 2 rue des Caillottes
F-89000 AUXERRE - FRANCE
T: + 33.3.86.49.86.30
F: + 33.3.86.46.42.10
contact@mouvex.com
mouvex.com



Hydrocar

Hydraulic Energy

Via A. Mingozzi
6 - 40012 Calderara di Reno (BO) - Italy
Tel.: +39 051 6460511

Where Innovation Flows



PSG reserves the right to modify the information and illustrations contained in this document without prior notice. This is a non-contractual document. 03-2019

Authorized PSG Partner: